



ComInTec®
Safety in Power Transmission

TORQUE LIMITER FOR GEARBOXES

up to 2,800 Nm and 65 mm bore diameters



ED. 07/2021 Rev.01



- Download catalogue
- Download instruction sheets
- Download 3D and 2D cad model

.../PR

.../PR - torque limiter for gearboxes: introduction

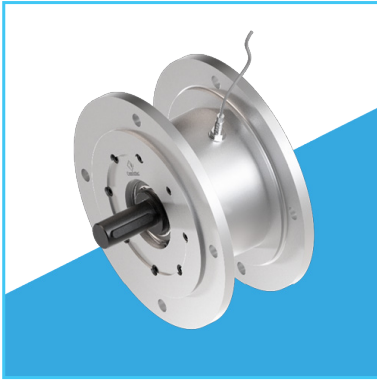

- ⦿ Safety coupling made in steel fully turned, spacer made in aluminium fully turned for IEC-B5 motors
 - ⦿ Standard treatment of phosphating on torque limiter.
 - ⦿ Compact solution.
 - ⦿ Model available for IEC motors and gearboxes.
 - ⦿ Protection in both directions.
 - ⦿ Instant disengagement upon overload.
 - ⦿ Fast and simple calibration using our "H" dimension procedure.
- ON REQUEST
- ⦿ Device calibrated and ready to use.
 - ⦿ Friction rings available in various materials and performance to suit specific needs.
 - ⦿ Free rotation backlash free balls model according to ATEX conformity.
 - ⦿ Various anti-corrosive surface treatments available.

Safety coupling to be mounted between the motor and gearbox with flanged B5 spacer. Available in sliding (DF/TAC/PR-V) and disengage versions (DSS/F/SG/PR-V or DSS/SG/RF/PR-V). The location of the limiter between the motor and gearbox requires a smaller size of device with also reduces costs.

■ MAIN APPLICATION

- ⦿ Conveyor.
- ⦿ Packaging machines.
- ⦿ Wrapping machines.
- ⦿ Motorized systems of handling and positioning.

■ ADVANTAGES AND BENEFITS

- ⦿ Simplicity and sensitivity compared to gearbox integrated solutions.
- ⦿ Protect the motor-gearbox from accidental collisions or impacts from the products being processed.
- ⦿ Greatly reduces production downtime in case of overload.
- ⦿ Absorb static torques without disengaging (friction model).

	<p>DSS/F/SG/PR-V: Backlash free balls model to fit between motor and gearbox.</p> <p>DSS/SG/RF/PR-V: Free rotation backlash free balls model according to ATEX 2014/4G/UE conformity. II 2G Ex II B T5 Gb -15 °C ≤ Ta ≤ + 80 °C</p>	<p>From 2 - 1,300 Nm of torque 65 mm max. bore / shaft</p>	<p>Pag. 53</p>
	<p>DF/TAC/PR-V: Friction model chain coupling version to fit between motor and gearbox.</p>	<p>From 1 to 1,650 Nm of torque 55 mm max. bore / shaft</p>	<p>Pag. 54</p>
	<p>DF/PR: Friction model to assemble directly into the output of the hollow shaft gearbox.</p>	<p>From 1 to 2,800 Nm of torque 65 mm max. bore 55 mm max. shaft</p>	<p>Pag. 55</p>

DSS/F/SG/PR-V and DSS/SG/RF/PR-V- backlash free balls model for gearboxes (input shaft): technical data

- Balls solution, torsional backlash free, maintenance free.
- Instant disengagement between driving part and driven part in the event of overload.
- Available with single point (360°) engagement or free rotation according to ATEX conformity (**DSS/SG/RF/PR-V**).
- Complete solution with connecting flanges in aluminum for IEC-B5 motors.
- Inductive sensor integrated for monitoring the overload.
- Torque range: 2-1,300 Nm; bore/shaft max $\varnothing 48$ mm.

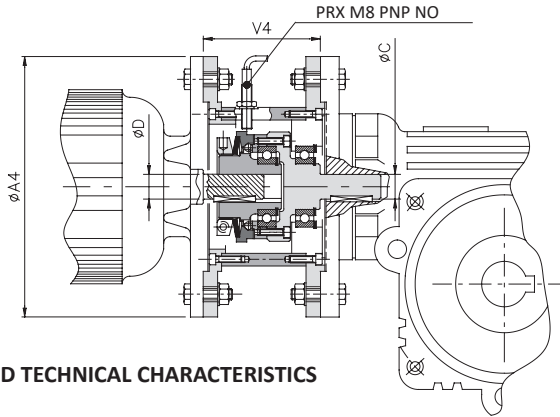

version DSS/SG/RF/PR-V
II 2G Ex II B T5 Gb -15°C ≤ Ta ≤ +80°C

DIMENSIONS AND TECHNICAL CHARACTERISTICS

T.L. size	D H7 C h7	Motor IEC	A4 B5 Flange	Model: DSS/F/SG/PR-V							Model: DSS/SG/RF/PR-V							
				Torque [Nm]				V4	Max speed [Rpm]	Weight [Kg]	Torque [Nm]				V4	Max speed [Rpm]	Weight [Kg]	
				T1	T2	T3	T4				T1	T2	T3	T4				
00.47	11	63	140	2-5,6	5,3-12	-	11-24	52,5	4000	3,5	-							
	14	71	160					55		4,2	-							
0.63	19	80	200	5-14	12-28	24-50	-	78	4000	8	5-14	10-30	20-50	-	86	4000	8	
1.80	24	90	200	9-28	18-60	40-100	-	90	3000	9	9-30	20-70	30-100	-	99	4000	10	
2.96	28	100-112	250	20-45	42-95	-	85-200	110	2500	17	20-54	40-95	-	80-200	121	4000	18,5	
▲ 3.116	38	132	300	35-100	75-200	-	195-415	110	2000	24	50-95	90-185	-	180-400	140	4000	29,5	
▲ 4.138	42	160	350	75-190	140-345	-	245-720*	126	1850*	33,5	70-190	125-345	-	300-720	148	3000	37,5	
▲	48	180							36	40								
▲ 5.172	55	200	400	-							192	3000	70					
▲	60	225	450								120-350			230-670	-	500-1300	192	80
▲	65	250-280	550								194			110				

* For calibrations over 350 Nm the maximum speed is reduced to 1200 Rpm

▲ On request

FITTING EXAMPLE

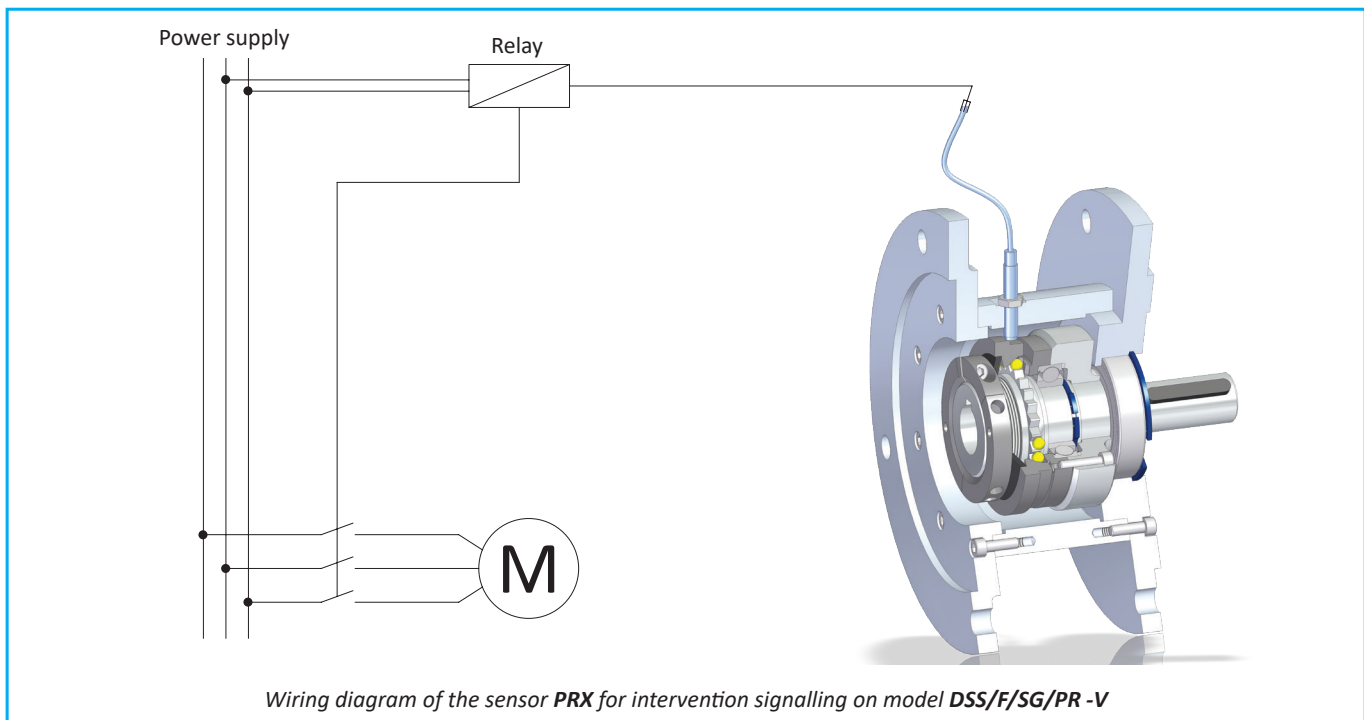

DF/TAC/PR-V - friction model with chain coupling for gearboxes (input shaft): technical data



- Compact and economic solution.
- Sliding of the driving part to overcome the torque calibration without disconnecting the transmission.
- Silent intervention and vibration-free.
- Complete solution with connecting flanges in aluminum for IEC B5 motors.
- Possibility of integration of an inductive sensor for monitoring the overload (DF/TAC/PR-V/S).
- Torque range: 1-1,650 Nm; bore/shaft max: $\varnothing 55$ mm.

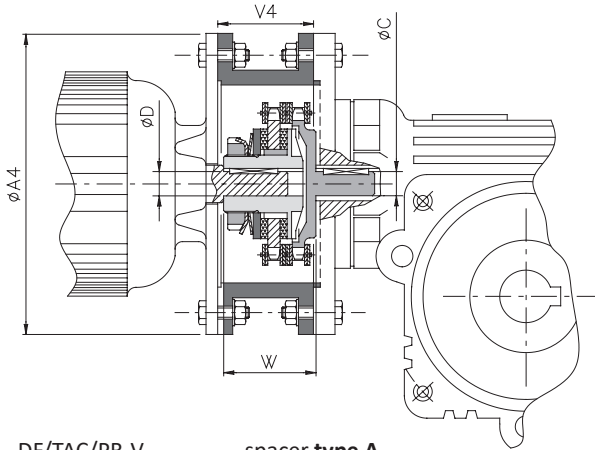

DF/TAC/PR-V → spacer type A (without sensor)
 (with inspection)

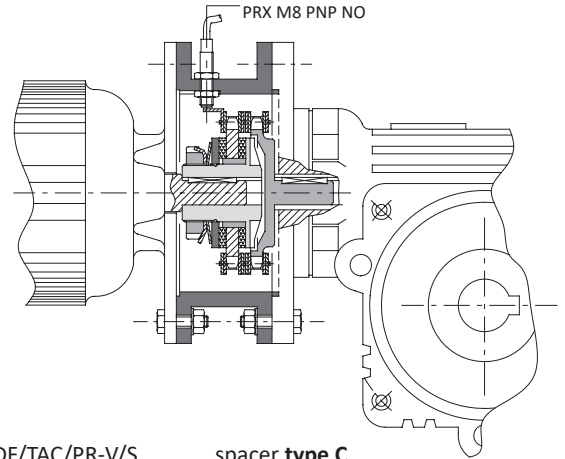

DF/TAC/PR-V/S → spacer type C (with sensor)
 (with inspection)

DIMENSIONS AND TECHNICAL CHARACTERISTICS

T.L. size	D H7 C h7	Motor IEC	A4 B5 Flange	Torque [Nm]				V4	W	Max speed [Rpm]	Weight [Kg]	
				T0	T1	T2	T3				limiters	spacer
00.38	11	63a	140	-	1 - 14	4 - 22	15 - 34	43	43	5000	0,6	0,5
	14 *	71a	160								0,6	
0.50	19	80a	200	2 - 12	9 - 42	25 - 70	46 - 90	45,5	45	3800	1	1
	24 *	90S						55,5			0,9	1,5
1.70	28	100La - 112M	250	4 - 20	15 - 80	30 - 150	80 - 230	66	64	2800	2,6	2,2
2.90	38	132M	300	12 - 85	55 - 160	95 - 290	175 - 450	83,5	72	2200	3,8	2,9
3.115	42	160L	▲ 350	65 - 265	130 - 380	200 - 700	290 - 950	121	104	1800	10,2	5,8
	48	180L									10,4	5,8
4.140	55	200L	▲ 400	-	95 - 700	200 - 1300	280 - 1650	122	104	1500	18	16,5

▲ On request

FITTING EXAMPLES

Model DF/TAC/PR-V for mounting between motor and gearbox complete with spacer type A and inspection.

Wiring diagram of the sensor PRX to intervention signaling on model DF/TAC/PR-V/S.

NOTES

- D H7 *: reduced keyway on torque limiter.

DF/PR and DF/TAC/PR - friction model for gearboxes (output shaft): technical data

ON REQUEST MODEL



- Possibility of friction rings with different performance for specific needs.
- Specifically designed for installation on hollow output shaft gearboxes.
- Available complete with transmission component fully turned and fitted.
- Available with radial nut (.../GR) statically balanced.
- Model for gearboxes with a chain coupling, suitable for connections of coaxial shafts (DF/TAC/PR).
- Torque range: 1-2,600 Nm; max shaft: $\varnothing 55$ mm; max bore: $\varnothing 65$ mm.

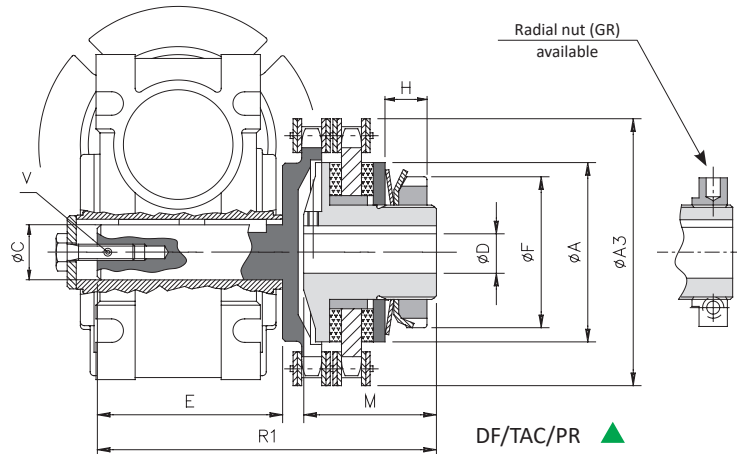
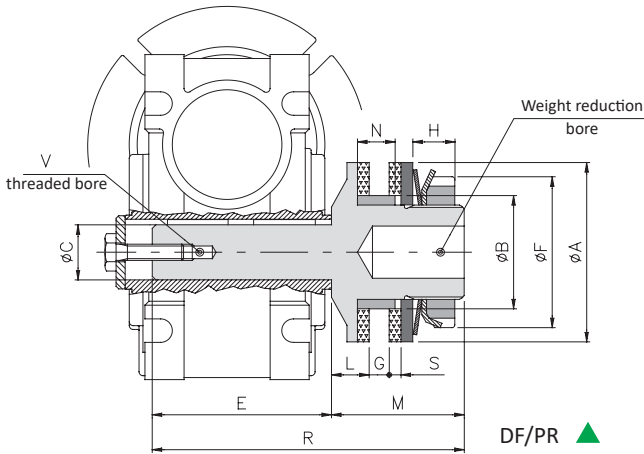

DIMENSIONS

Size	A3	A	B h7	C h7	DH7 max	E	F	G		L	M	N	R	R1	S	V
								min	max							
00.38	57	38	24	11	12	48	32	2,5	5	8	33	8	81	91	2,5	M4x10
0.50	75	50	36	14	20	53	44	3,5	6	10	35	10	88	98	3	M5x13
1.70	101	70	45	18	25	62	63	5	10	15	55	15	117	126	4	M6x16
				19		78							133	142		
				24		90							145	154		
				25		80							135	144		
2.90	126	90	60	25	38	90	82	7	12	16	60	17	150	164	4	M8x20
				28		110							170	182		
3.115	159	115	72	32	45	120	104	9	16	18	70	21	190	212	4	M10x25
				35		118							188	210		
				38		138							208	230		
4.140	184	140	85	42	55	152	130	13	19	20	80	25	232	258	5	M12x32
				45		163							243	269		
				48		178							258	284		
5.170	215	170	98	50	65	167	158	15	22	22,5	95	28	262	286	5	M16x40
				55		202							303	327		

TECHNICAL CHARACTERISTICS

Size	Torque [Nm]				Max speed [rpm]		Weight [kg]	
	T0	T1	T2	T3	DF/PR	DF/TAC/PR	DF/PR	DF/TAC/PR
00.38	-	1 - 14	4 - 22	15 - 34	10000	5000	0,2	0,6
0.50	2 - 12	9 - 42	25 - 70	46 - 90	7600	3800	0,4	1,0
1.70	4 - 20	15 - 80	30 - 150	80 - 230	5450	2800	1,2	2,8
2.90	12 - 85	55 - 160	95 - 290	175 - 450	4250	2200	2,2	5,7
3.115	65 - 265	130 - 380	200 - 700	290 - 950	3350	1800	3,9	10,7
4.140	-	95 - 700	200 - 1300	280 - 1650	2750	1500	7,3	19,3
5.170	-	100 - 950	600 - 1900	800 - 2800	2250	1300	12,1	29,8

NOTES

▲ On request

- Weight refer to the torque limiter pilot bore.

.../PR - torque limiter for gearboxes: additional information

ORDER EXAMPLE

TORQUE LIMITER FOR GEARBOXES					DRIVE ELEMENT (ref. to DF/PR)
Size	Model	Spacer	Shaft / Bore	Torque/Springs	Description
0.50	DF/TAC/PR-V	with type A spacer	ø28 h7/H7	20 Nm	Simple plate wheel 3/8" x 7/32" Z=22

Size	Model	Spacer	Springs
da 00.38 a 5.170	DSS/F/SG/PR-V	● Spacer (ref. to TAC/PR-V)	T0
da 00.47 a 4.138	DSS/SG/RF/PR-V (ATEX)	Type A	T1
	● DF/TAC/PR-V		T2
	● DF/TAC/PR-V/S		T3
	DF/PR		T4

- DF/TAC/PR-V model is supply combined with the corresponding spacer (type A)
- DF/TAC/PR-V/S model is supply combined with the corresponding spacer (type C), complete with inductive proximity sensor (PRX).

PRX - inductive proximity sensor: technical data



- ⊙ Standard version: Stainless steel cover with protection level IP67 DIN 40050.
- ⊙ Electric contact: 7 ÷ 30 Vdc. - Frequency: 4 KHz; Absorption ≤ 10 mA (Max 200mA).
- ⊙ Operation temperature range from -25°C to +70°C
- ⊙ Output: NPN (N.O.-N.C.) – PNP (N.O.-N.C.).
- ⊙ Operating distance: max 1,5 mm.
- ⊙ Cable length: 2 m (3x0,2).

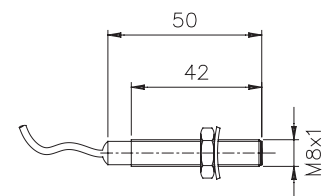
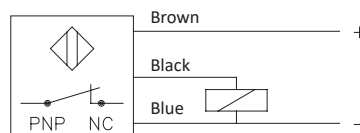
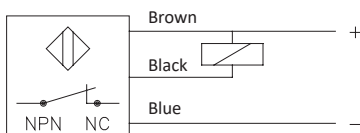
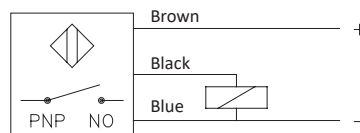
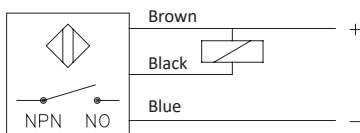

Weight: 50g

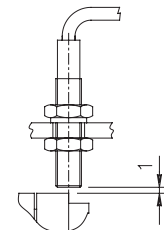

PRX-EX - ATEX proximity induced sensor



- ⊙ Housing in nickel-plated brass with IP67 - DIN 40050 protection clearance.
- ⊙ Voltage 8.2 Vdc (1K0hm).
- ⊙ Operating temperature from -25°C to +60°C.
- ⊙ Intervention distance: max 1 mm.
- ⊙ Cable length: 3 meters (2x0.25).

