

## .../TAC (version with chain coupling): technical data

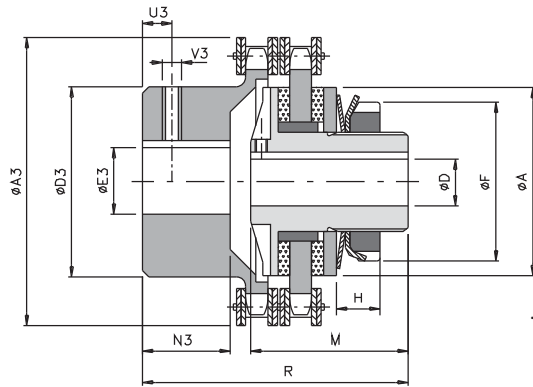

.../GR (radial nut available from size 00.38)



### DIMENSIONS AND TECHNICAL DETAILS

Size	Torque [Nm]	A	D H7		F	M	R	A3	D3	E3 H7		N3	U3	V3	Max speed [Rpm]	Weight [Kg]
			pilot bore	max.						pilot bore	max.					
00.25	1 - 20	25	-	8	22	26	39	45	23	8	12	9	4	M3	5000	0,2
00.38	1 - 34	38	-	12	32	33	58	57	37	10	20	20	5	M3	5000	0,6
0.50	2 - 100	50	-	20	44	35	58	75	50	12	28	19	8	M4	3800	1,1
1.70	6 - 210	70	-	25	63	55	87	101	70	16	38	29	12	M6	2800	2,8
2.90	13 - 450	90	-	38	82	60	102	126	89	20	55	38	12	M6	2200	5,9
3.115	26 - 950	115	18	45	105	70	131	159	112	20	70	56,5	15	M8	1800	11,1
4.140	80 - 1200	140	24	55	130	80	145	184	130	28	80	59,5	15	M8	1500	20,3
5.170	160 - 2600	170	28	65	158	95	189	215	130	30	80	88	15	M8	1300	31,0

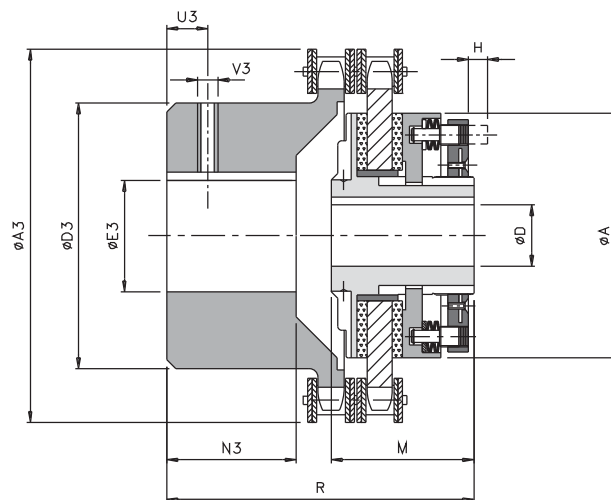

### DIMENSIONS AND TECHNICAL DETAILS

Size	Torque [Nm]	A	D H7		M	R	A3	D3	E3 H7		N3	U3	V3	Max speed [Rpm]	Weight [Kg]
			pilot bore	max.					pilot bore	max.					
6.205	300 - 4800	205	38	80	110	218	291	150	38	90	103	25	M10	1000	54,6
7.240	500 - 8000	240	50	100	116	245	310	170	50	110	124	25	M10	900	76,7
8.300	800 - 14000	300	60	120	123	284	374	200	50	140	147	30	M12	700	125,5
9.340	1000 - 18000	340	60	130	158	329	423	210	60	150	165	30	M12	600	180
10.400	1500 - 23000	400	60	140	167	364	471	240	60	160	191	30	M16	550	260



▲ On request

### NOTES

- ⊗ **Technical details:** data is relevant to the whole group (DF/TAC).
- ⊗ **Technical details:** weights are relevant to the whole group with pilot bore (DF/TAC).

# FRICION TORQUE LIMITER "DF": additional information

## TORQUE TRANSMISSION

Torque transmission [Nm] relevant to the springs configuration									
Size	A1S1 )	A2S2 )	A3S3 )	A1M1 )	A1G1 )	A2G2 )	A3G3 )	ST 	SQ 
00.25	1 - 8	2 - 12	2 - 20						
00.38	1 - 14	8 - 22	15 - 34						
0.50	2 - 12				4 - 40	17 - 70	23 - 100	1,5 - 9	
1.70	6 - 18			9 - 35	19 - 60	34 - 120	60 - 210	2 - 34	2 - 60
2.90				13 - 105	74 - 140	90 - 280	185 - 450	5 - 56	3 - 70
3.115	26 - 100 *			65 - 280	120 - 360	207 - 700	210 - 950	10 - 130	25 - 160
4.140	80 - 140 *			100 - 240 *	180 - 550	260 - 950	390 - 1200		
5.170					160 - 700	300 - 1450	1000 - 2600		

Size	A4M1 (())	A4G1 (())	A4G2 (())						
6.205	300 - 1200	500 - 2400	1000 - 4800						
7.240	500 - 2000	1000 - 4000	2000 - 8000						
8.300	800 - 3500	1500 - 7000	3000 - 14000						
9.340	1000 - 4500	2000 - 9000	4000 - 18000						
10.400	1500 - 5000	3000 - 11000	5000 - 23000						

\* Until stocks are finished

## ORDER EXAMPLE

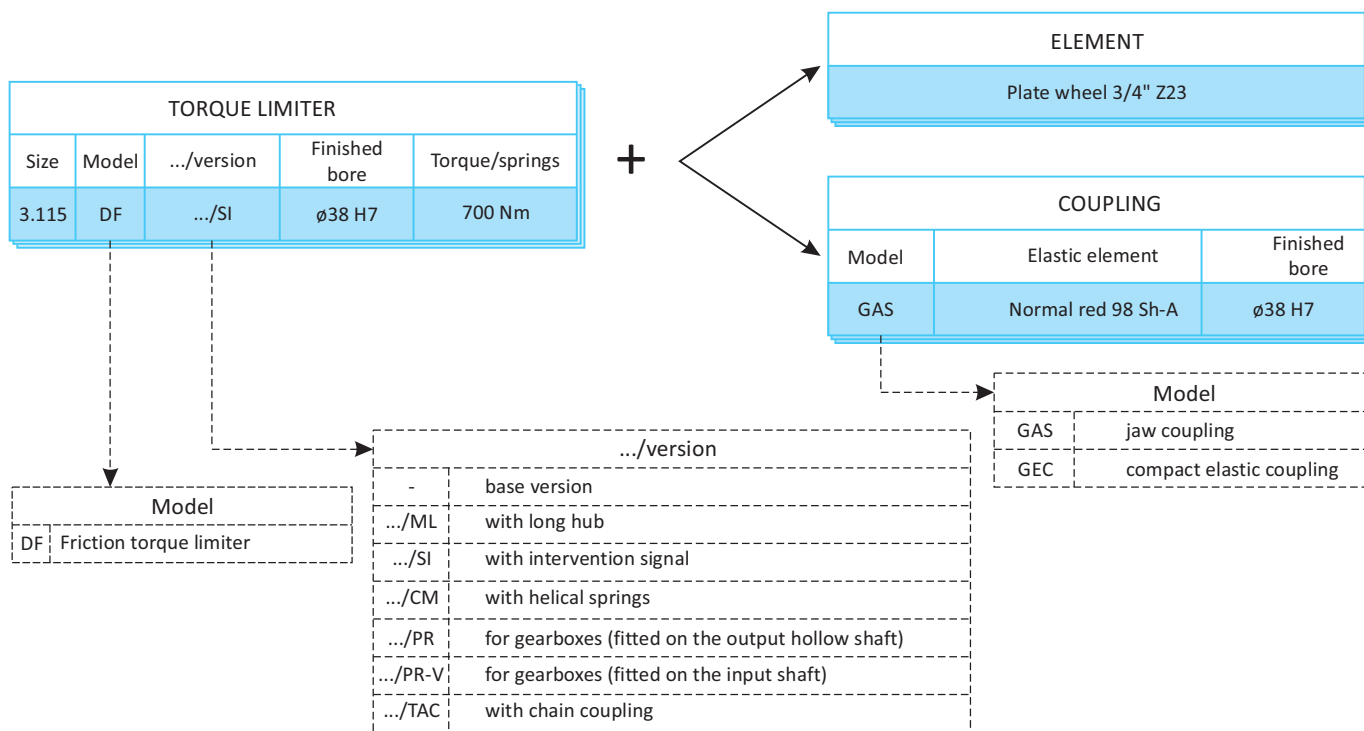

# FRICION TORQUE LIMITER "DF": additional information

## PLATE WHEELS

The driving part selected (plate wheels, pulleys, gears, and so on) to be incorporated into the friction torque limiter, must adhere to predetermined characteristics (ex. the surface in contact to the friction rings with roughness  $Ra=0,8 : 1,6$ ) to ensure good performance. In the table below, there are standard plate wheels in ComInTec's production (supplied already grounded) which can be assembled on the torque limiter; **and the minimum chain passage "V" (see picture 3)**, necessary for the correct sizing of the plate wheel to avoid contact between the chain and outside diameter of the limiter. It is possible to assemble various types of plate wheels, but the surfaces must be machined, and the chain passage cannot be smaller than this value. Another aspect to take into consideration to ensure the dimension of the assembly is correct, is the element thickness and its relevant bush "N" (see picture 1). We suggest to obtain a quote "N" equal to  $[S + G + 1]$ . Comparing "N" value obtained, to the  $N_{std}$  indicated on the table, which corresponds to the standard length of the bushes, you can have: "N" < " $N_{std}$ " (picture 1 - ex.A) → reduce the bush width to quote "N".

"N" > " $N_{std}$ " (picture 2 - exB) → machine the driving part at a diameter of "A+1" and a depth equal to "x" ( $N - N_{std}$ ).

Example "A" (see picture 1)  
 1.70 with plate wheel #7  
 $G = 7 \text{ mm}$   
 $S = 4 \text{ mm}$   
 $N = S + G + 1 = 4 + 7 + 1 = 12$   
 $N_{std} = 15$   
 Reduce the bush width to 12 mm.

Example "B" (see picture 2)  
 1.70 with plate wheel #13  
 $G = 13 \text{ mm}$   
 $S = 4 \text{ mm}$   
 $N = S + G + 1 = 4 + 13 + 1 = 18$   
 $N_{std} = 15$   
 Machine  $\varnothing 71$  with depth (value "x"= $18-15=3$ )

where:  
 $p$  = pitch [in]  
 $G$  = thickness of the ground element  
 $Z$  = teeth number  
 $dp$  = pitch diameter  
 $S$  = thickness of the friction ring  
 $N_{std}$  = thickness of the standard bush  
 $N$  = thickness of the calculated bush ( $S+G+1$ )  
 $A$  = outside diameter of the torque limiter  
 $V$  = inside diameter of the chain  
 $x$  = depth of the machining ( $N - N_{std}$ )

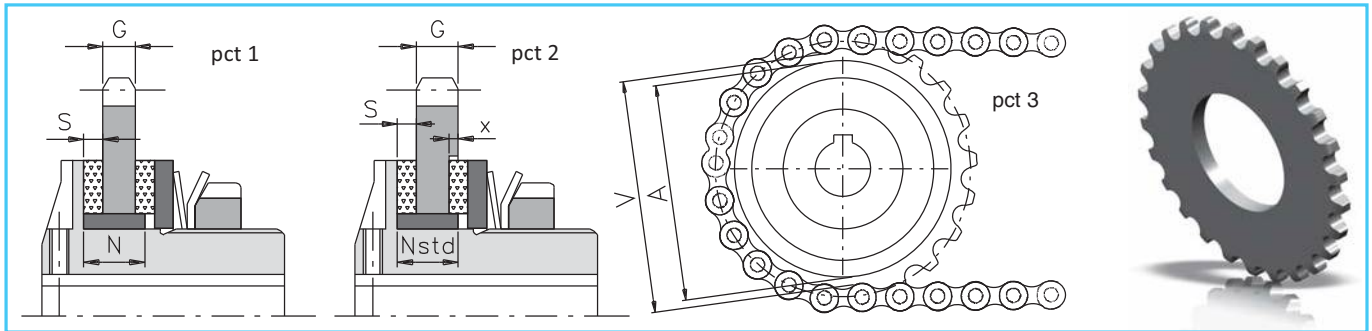

Size	P [in]	G [mm]	Z	dp [mm]	S [mm]	N Std [mm]	A [mm]	V [mm]	Code for single plate wheel		
									DF DSF/TF/AP	DF/SI DSF/TF/AP/SI	EDF/F
00.25	3/8"	5,1	12	36,80	2	5,5	25	28	580419851P05	-	-
00.38	3/8"	5,1	16	48,82	2,5	8	38	41	580406900P05	-	580406951P05
			20	60,89					580406400P05	-	580406451P05
0.50	3/8"	5,1	22	66,93	3	10	50	53	580406500P05	-	580406551P05
			22	66,93					580403700P05	580407700P20	580403751P05
1.70	1/2" x 5/16"	7,0	22	89,24	4	15	70	73	580404200P05	-	-
			19	96,45					580404700P05	-	-
2.90	1/2" x 5/16"	7,0	26	105,36	4	17	90	94	580404700P05	-	-
			18	109,71					580440100P05	580442100P20	580440151P05
3.115	3/4"	10,9	23	139,9	4	21	115	119	580404900P05	-	-
			17	138,22					580440200P05	580442200P20	580440200P05
4.140	3/4"	10,9	28	170,13	5	25	140	144	580405500P05	-	-
			20	162,38					580440300P05	580442300P20	580440351P05
5.170	1"	16,0	24	194,59	5	28	170	175	580440400P05	580442400P20	-
			20	202,98					580417200P05	-	-
▲ 6.205	1" 1/4	18,3	26	263,40	5	32	205	210	580406200P05	580407600P20	-
▲ 7.240	1" 1/4	18,3	28	283,56	5	35	240	245	580406300P05	580407700P20	-
▲ 8.300	1" 1/2	23,8	28	340,27	6	40	300	306	580407000P05	580407300P20	-
▲ 9.340	1" 1/2	23,8	32	388,69	6	40	340	355	580407100P05	580407400P20	-
▲ 10.400	1" 1/2	23,8	36	437,16	6	42	400	403	580407200P05	580407500P20	-

▲ On request

## VERSIONS ON REQUEST

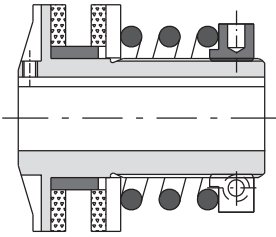

### .../CM: minimum torque version

Helical springs execution, for a higher torque range and consequently, a finer adjustment on calibration is possible

STAINLESS STEEL discs

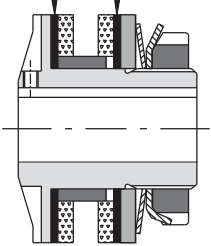

### .../EA: rust resistant

Rust resistant execution, with stainless steel rings, galvanized for application in wet environments.

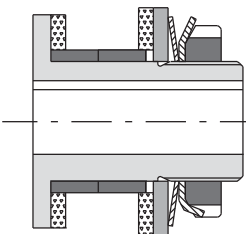

### .../MFR: reduced flange hub version

Reduced flange hub execution, to assemble elements with reduced diameters. Available with two or three bushes version.

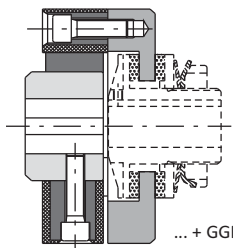
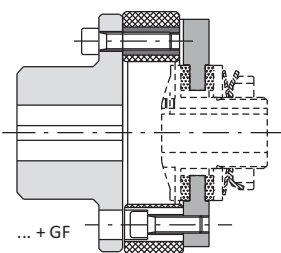

### DF + GF: with flexible coupling DF + GGF: with highly flexible coupling

Models suitable for an in-line shafts connection and also able to accommodate high misalignments.

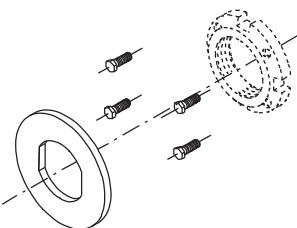

### GT/DR KIT: kit for double registration matching to the nut with notches GT

Torque adjustment system by double registration (flange plus hexagonal head-screws) for high sensitivity and precision on calibration, also with belleville washers.

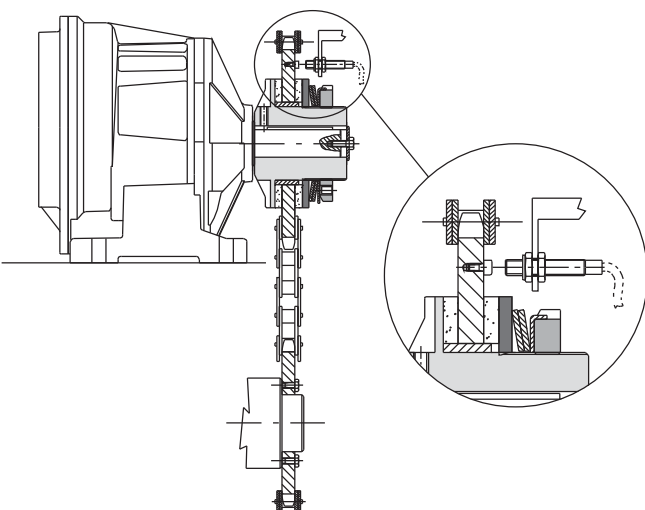

### .../MS: overload detection version

Our suggestion to increase the life of the friction rings and to maintain the torque limiter efficiency is (it is possible and advised) to stop the machine immediately, on the first slip caused by an overload. This is possible by using one proximity inductive sensor, which registers any speed anomaly, as indicated in the picture.







# "DF" FRICTION TORQUE LIMITER: introduction



- Simple and economic friction torque limiter.
- Suitable for dusty conditions without need of timing between gearbox and output.
- Silent overload without vibration.
- Protection in both rotation directions.
- Asbestos-free friction discs.
- Simple and precise torque setting by adjusting the locking ring.
- The innovative setting by the "H" dimension allows for immediate calibration.

### ON REQUEST

- Complete with transmission gear, fully turned and mounted (plate wheel, pulley, gear).
- Different types of friction discs for specific applications.
- Possibility of connections with bore and keyway, locking assembly or other locking systems.
- Anti-corrosive surface treatments for special requirements.

	DF: Basic model for parallel shaft transmission, with plate wheels, gear pairs or pulleys.	from 1 to 23000 Nm max. bore $\varnothing$ 140 mm	Page 5
	DF/SI: signaling on overload and automatic re-engaging possible.	from 3 to 23000 Nm max. bore $\varnothing$ 140 mm	Page 6
	DF/TAC: in-line shaft connection, simple and economic.	from 1 to 23000 Nm max. bore $\varnothing$ 140 mm	Page 7
	... + GAS: in-line shaft connection with elastic coupling with high misalignments.	from 1 to 7200 Nm max bore $\varnothing$ 110 mm	Page 8
	... + GEC: in-line shaft connection with compact elastic coupling.	from 1 to 800 Nm max bore $\varnothing$ 160 mm	Page 8
	DF/PR: designed for the application on the slow speed shaft of a worm-gearbox.	from 1 to 2600 Nm max. bore $\varnothing$ 55 mm	Page 9
	DF/TAC/PR-V: designed for application on the high speed shaft of a worm-gearbox.	from 1 to 1200 Nm max. shaft - bore $\varnothing$ 55 mm	Page 10

## MAIN APPLICATIONS

- Forming machines.
- Conveyors.
- Automotive.
- Agricultural machines, woodworking machines.

## ADVANTAGES AND BENEFITS

- Protects the motor-gearbox in case of accidental collision.
- Protects the film of wrapping machines in case of higher tension.
- Absorbs static torques without disengaging.
- Protects the gear in case of short product jam.

## FRICTION RINGS

- **STD (standard)**: friction rings used for the torque values indicated in the catalogue. Optimum performance ratio torque / life.
- ▲ ○ **LD (long life)**: same performance in torque respect std friction rings life greater than 5 times.
- ▲ ○ **LDX (extra long life)**: life greater than 150 times respect standard friction rings, but performance in torque reduce of 70%.
- ▲ On request

## APPLICATION EXAMPLES

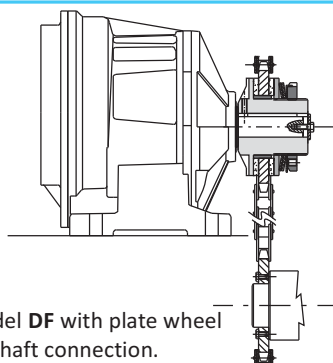

Friction Model **DF** with plate wheel for parallel shaft connection.

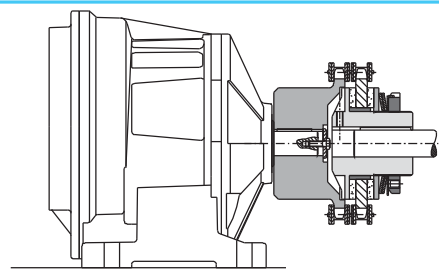

Friction Model with chain coupling **DF/TAC** for in-line shafts connection.

# ELECTROMECHANICAL SWITCH "EM1"

- Die-cast aluminium box with rotection level **IP57** DIN 40050.
- Adjustment of the lever end position possible.
- Operation temperature range from  $-10^{\circ}\text{C}$  to  $+85^{\circ}\text{C}$ .
- Three different options of voltage input: 15A-250VCA; 5A-24VCC; 0,2A-250VCC.
- 1 or 2 contacts available.
- Initial stroke 0,5 mm, Extra stroke:  $4 \div 8$  mm depending on setting (possible in a range of 6 mm).

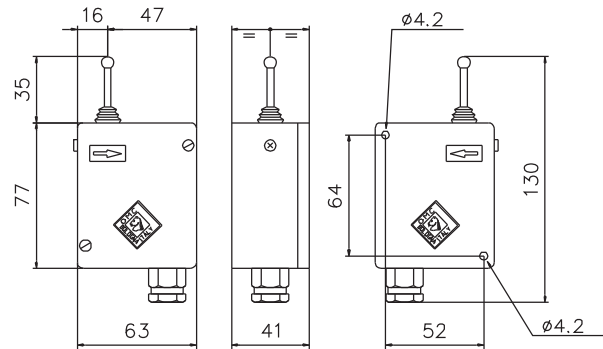
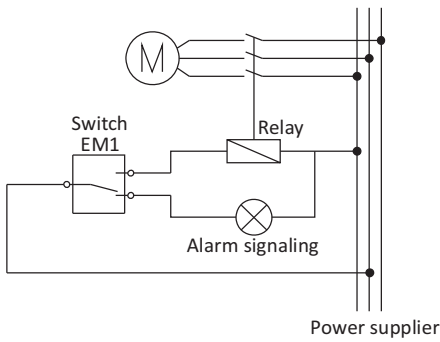

Weight: 350g

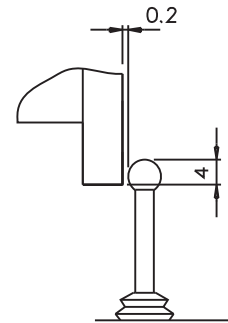

## PROXIMITY SENSOR "PRX"

- Standard version: Brass cover with protection level **IP67** DIN 40050.
- Electric contact:  $5 \div 24$  VdC.
- Frequency: 2000 Hz.
- Output: NPN (N.O.-N.C.) – PNP (N.O.-N.C.).
- Operating distance: max 1 mm.
- Cable length: 2 m (3x0,2).

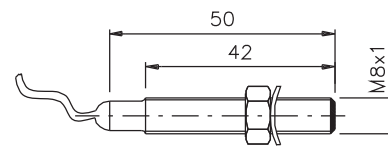
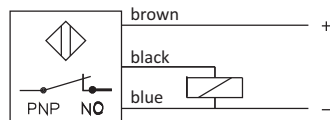
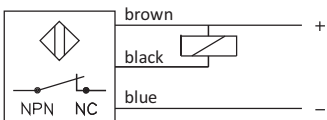
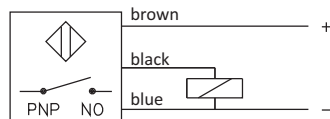
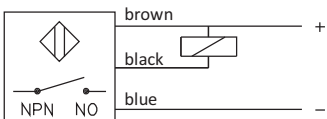

Weight: 50g

