

... + GTR (model with torsionally rigid disc coupling): technical data

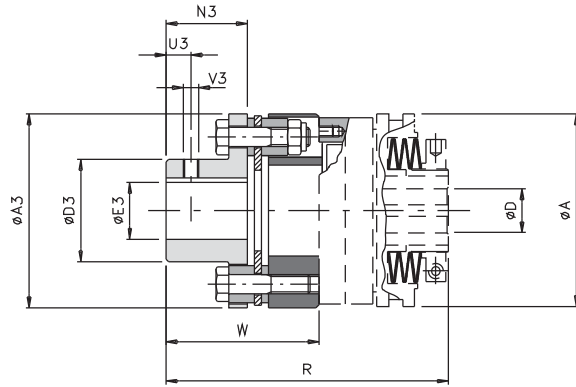

DIMENSIONS AND TECHNICAL DETAILS

Size		Torque [Nm]		A3	D3	E3 H7 max	N3	U3	V3	A	D H7		R	W	Misalignments			Stiffness [Nm/rad·10 ⁴]	Max. speed [Rpm]		Weight [Kg]
DSS	DSR	GTR	Nom								Max	pilot bore			max.	Angular α [°]	Axial X [mm]		Radial K [mm]	DSS	
0.56	0	60	120	78	45	32	29	10	M5	56	-	20	105	59	1°	1,40	0	80	4500	1500	1,4
1.90	2	150	300	92	53	38	42	10	M5	90	-	28	137	74	0° 45'	0,95	0	156	3000	1000	2,1
2.110	3	300	600	112	65	45	46	15	M8	110	-	40	161	85	0° 45'	1,25	0	415	2500	800	3,9
3.130	4	700	1400	136	75	52	56	15	M8	130	20	50	186	98	0° 45'	1,45	0	970	2000	700	5,8
4.160	5	1100	2200	162	92	65	66	20	M8	160	25	58	223	116,5	0° 45'	1,65	0	1846	1600	550	10,8
5.194	7	2600	5200	206	130	90	92	20	M10	194	28	68	270	145,5	0° 45'	2,25	0	3511	1300	400	21,9

... + GAS (model with jaw elastic coupling): technical data

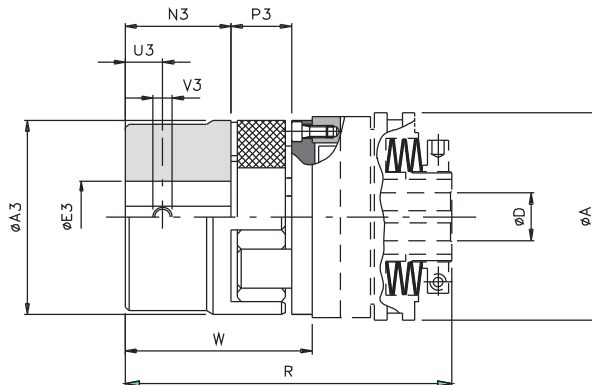

DIMENSIONS AND TECHNICAL DETAILS

Size		Torque [Nm]		A3	E3 H7 max	N3	P3	U3	V3	A	D H7		R	W	Misalignments			Max. speed [Rpm]		Weight [Kg]	
DSS	DSR	GAS									Pilot bore	max.			Angular α [°]	Axial X [mm]	Radial K [mm]	DSS	DSR		
		Std	▲ Min	Nom.	Max.																
0.56	0 (24)	00 (19)	60	120	55	35	30	18	10	M5	56	-	20	103	57	1° 18'	1	0,22	4500	1500	0,8
1.90	2 (38)	0 (24)	325	650	80	48	45	24	15	M8	90	-	28	141	78	1° 18'	1,4	0,28	3000	1000	3,7
2.110	4 (48)	1 (28)	525	1050	105	62	56	28	20	M8	110	-	40	171	95	1° 18'	1,7	0,36	2500	800	5,2
3.130	5 (55)	2 (38)	685	1370	120	74	65	30	20	M10	130	20	50	198	110	1° 18'	1,8	0,38	2000	700	9,1
4.160	7 (75)	4 (48)	1465	2930	160	95	85	40	25	M10	160	25	58	249	142	1° 18'	2,5	0,48	1600	550	17,9
5.194	8 (90)	5 (55)	3600	7200	200	110	100	45	30	M12	194	28	68	288,5	164	1° 18'	2,8	0,50	1300	400	29,5
▲ 6.240	9 (100)	-	3300	6600	225	115	110	50	30	M12	240	50	90	326	185	1° 18'	3,0	0,52	-	300	-
▲ 7.280	10(110)	-	4800	9600	255	125	120	55	33	M16	280	50	120	412	212	1° 18'	3,2	0,55	-	200	-

NOTES

▲ On request

- ⊗ Technical details: details are relevant to only for the coupling (GTR-GAS), for torque limiter details see on page 19.
- ⊗ Technical details: weights are relevant to only for the coupling (GTR-GAS) pilot bore.

BALL OR ROLLER TORQUE LIMITER "DSS/DSR": additional information



TORQUE TRANSMISSION

Torque transmitted [Nm] according to the spring configuration									
Size		A6S1 	A5M1 	A6M1 	A6M2 	A5G1 	A6G2 	ST 	SQ
0.56	DSS	2,5 - 9,5		5,5 - 17,5	15 - 32			0,8 - 10,9	
	DSR	10 - 20		14 - 37	30 - 75			1,9 - 25,6	
1.90	DSS	18 - 48	24 - 55			35 - 90	55 - 155	2 - 40	5 - 90
	DSR	30 - 60	45 - 100			85 - 180	170 - 350	8 - 75	8 - 145
	DSR/F/RF	25 - 55	45 - 95			80 - 155			
2.110	DSS		19 - 72			55 - 160	80 - 290	9 - 50	12 - 100
	DSR		60 - 150			142 - 330	275 - 620	12 - 90	25 - 190
	DSR/F/RF		90 - 210			100 - 360			
3.130	DSS	40 - 100 *	50 - 225			70 - 300	130 - 540	12 - 135	24 - 190
	DSR	75 - 180 *	115 - 370			200 - 510	430 - 900	30 - 300	50 - 320
	DSR/F/RF	80 - 165 *	120 - 390			120 - 450			
4.160	DSS	70 - 200 *	90 - 325 *			150 - 690	300 - 1280		
	DSR	160 - 335 *	210 - 540 *			330 - 1040	750 - 1800		
	DSR/F/RF	125 - 310 *	190 - 550 *			310 - 1060			
5.194	DSS					360 - 1040	460 - 2050		
	DSR					540 - 1620	1050 - 2800		
	DSR/F/RF					430 - 1460			

Size		A12S1 	A14S1 	A15G1 	A16G1 				
6.240	DSR	1600 - 3800		2000 - 8000					
7.280	DSR		2000 - 5600		2500 - 12000				

* Until stocks are finished

ORDER EXAMPLE

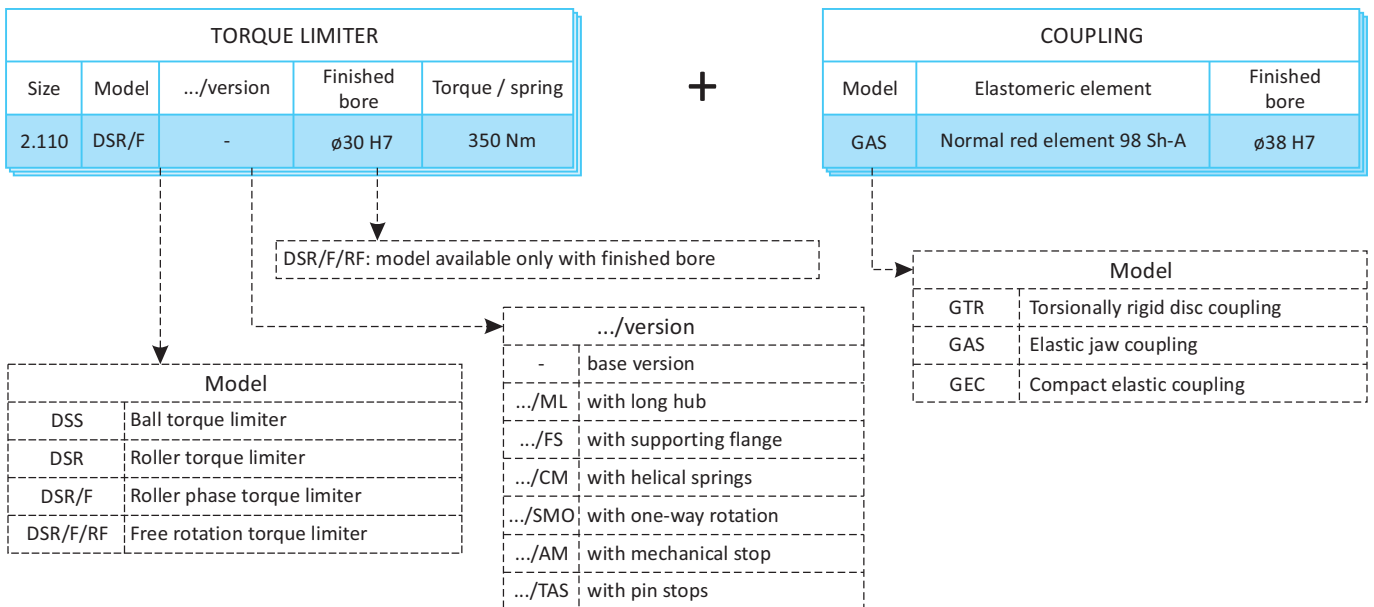

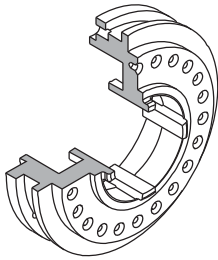

DSS: Ball torque limiter with optimum sensitivity in case of sudden torque variations

- Ball transmission.
- High sensitivity and immediate intervention in case of minimal torque variation.
- Equidistant automatic re-engagement.
- Torque range from 2,5 to 2050 Nm; max. bore \varnothing 68 mm.
- Same intervention torque in both directions.

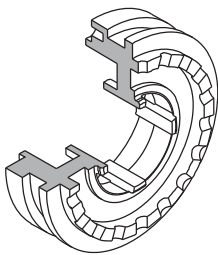

DSR: Roller torque limiter for steady transmission at high torques and vibrations

- Roller transmission.
- Equidistant automatic re-engagement.
- High torque settings at reduced dimensions.
- Torque range from 10 to 12000 Nm; max. bore \varnothing 120 mm.
- Same intervention torque in both directions.

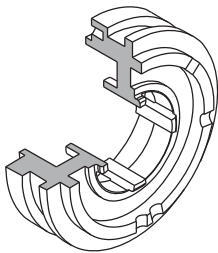

DSR/F: Roller phase torque limiter, synchronised connection between input and output.

- Roller transmission.
- Optimized roller arrangement (patented) with perfect stability and 3 point contact.
- Automatic re-engagement in phase 360° or personalized (30°, 45°, 60°, 90°, 120°, ...)
- High torque settings at reduced dimensions.
- Torque range from 10 to 12000 Nm; max. bore \varnothing 120 mm.

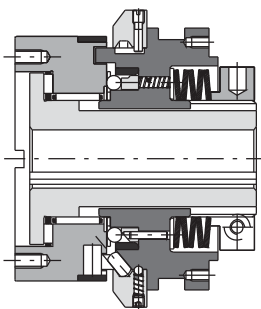

DSR/F/RF: roller phase torque limiter free rotation after disengagement, until inertial forces are stopped

- Roller transmission.
- Free rotation after disengagement.
- one engagement in 360°.
- Same intervention torque in both directions.
- Torque range from 2,5 to 2800 Nm; max. bore \varnothing 68 mm.

NUMBER OF RE-ENGAGEMENT IN 360°

Model	Size							
	0.56	1.90	2.110	3.130	4.160	5.194	6.240	7.280
DSS	24	22	20	20	22	15	-	-
DSR	18	18	16	16	16	24	24	24
DSR/F	1	1	1	1	1	1	1	1
DSR/F/RF	-	1	1	1	1	1	-	-

VERSIONS

Example: DSR/F/SMO DX

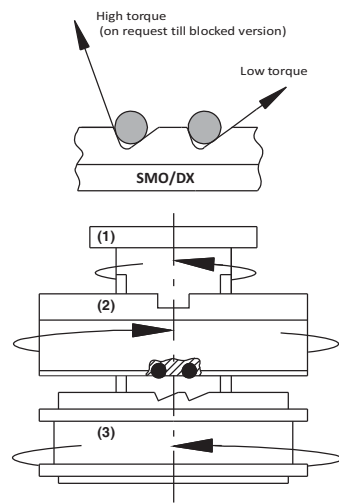

DSR/SMO: Torque limiter with different disengagement torques from clockwise to anti-clockwise rotation.

- ⊙ Different intervention torques in the two rotation directions.
- ⊙ Locking of one direction possible.
- ⊙ Roller transmission with automatic re-engagement.
- ⊙ Available with equidistant re-engagement or personalized angular phases.
- ⊙ Torque range from 10 to 12000 Nm; max. bore \varnothing 120 mm.

DSR/SMO and DSR/F/SMO: determination of the rotation direction

To allow our engineers to select the correct direction "SX" or "DX" for your application, we require a drawing showing:

- 1) How the unit will be mounted on to the shaft (orientation).
- 2) The direction of rotation.
- 3) In which direction the high/low torque is required.



Example: DSR/F/AM DX

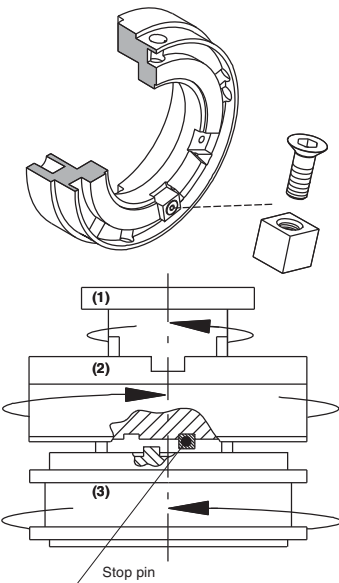

DSR/F/AM: DSR/F/AM: Torque limiter with mechanical disconnection to maintain the timing between driver and driven

- ⊙ Stop pin resists 4 times the maximum torque.
- ⊙ 345° rotation allows the cancellation of the residual torque before the device stops.
- ⊙ Maintains the timing and re-engages in the same position.
- ⊙ High torque settings at reduced dimensions.
- ⊙ Torque range from 10 to 2800 Nm; max. bore \varnothing 68 mm.

DSR/F/AM: determination of the rotation direction

To allow our engineers to select the correct direction "SX" or "DX" for your application, we require a drawing showing:

- 1) How the unit will be mounted on to the shaft (orientation).
- 2) The direction of rotation.
- 3) Confirm which drive will continue to rotate after the overload, the shaft or platewheel, pulley, etc.

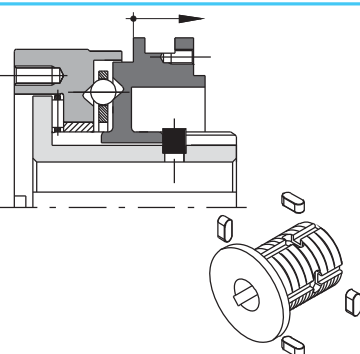

.../TAS: Torque limiter with stop pins

- ⊙ Complete disconnection prevented.
- ⊙ Minimum movement of the mobile base for an electrical signal to stop transmission.
- ⊙ Roller or ball transmission.
- ⊙ Torque range from 2,5 to 2800 Nm; max. bore \varnothing 68 mm.
- ⊙ Suitable for applications where the drive must not be disconnected.

BALL AND ROLLER TORQUE LIMITERS “DSS or DSR”: introduction



- ⊙ Precise torque setting by adjusting the radially balanced locking nut.
- ⊙ The innovative regulation by the “H” dimension allows for immediate calibration.
- ⊙ Equidistant re-engagement in phase or at 360°.
- ⊙ Available with electromechanical switch / proximity for the transmission disconnection.
- ⊙ Immediate intervention for an improved reaction compared to electronic systems.
- ⊙ Maintenance-free for long lasting high reliability.
- ⊙ Suitable for oily and wet environments.

ON REQUEST

- ⊙ Complete with transmission gear, fully turned and mounted (plate wheel, pulley, gear pair).
- ⊙ Possibility to use helical springs for low intervention torques.
- ⊙ Connections with bore and keyway, locking assembly possible.
- ⊙ Version with personalized re-engagement in phase 30°, 45°, 60°, 90°... possible.

	DSS or DSR: basic model for coupling connections.	from 2,5 to 12000 Nm max. bore ø120 mm	Page 19	Models and versions described on pages 17 and 18
	.../FS: for the assembly of simple transmission elements.	from 2,5 to 12000 Nm max. bore ø120 mm	Page 20	
	DSR/F/RF: mechanical model with free rotation and phase 360°.	from 25 to 1460 Nm max. bore ø68 mm	Page 21	
	... + GTR: connection with torsionally rigid coupling.	from 2,5 to 2800 Nm max. bore ø90 mm	Page 22	
	... + GAS: connection with elastic coupling with high misalignments.	from 2,5 to 2800 Nm max. bore ø110 mm	Page 22	
	... + GEC: connection with elastic coupling with low misalignments.	from 2,5 to 12000 Nm max. bore ø180 mm	Page 23	

MAIN APPLICATIONS

- ⊙ Packaging and wrapping machines.
- ⊙ Labelling machines.
- ⊙ Bottling machines.
- ⊙ Conveyors.

ADVANTAGES AND BENEFITS

- ⊙ Protects the gearbox from jamming due to foreign matters.
- ⊙ Protects packages from squashing and deforming.
- ⊙ Protects the product handling elements from accumulations.
- ⊙ Maintains the timing between driver and driven after an overload.

APPLICATION EXAMPLE

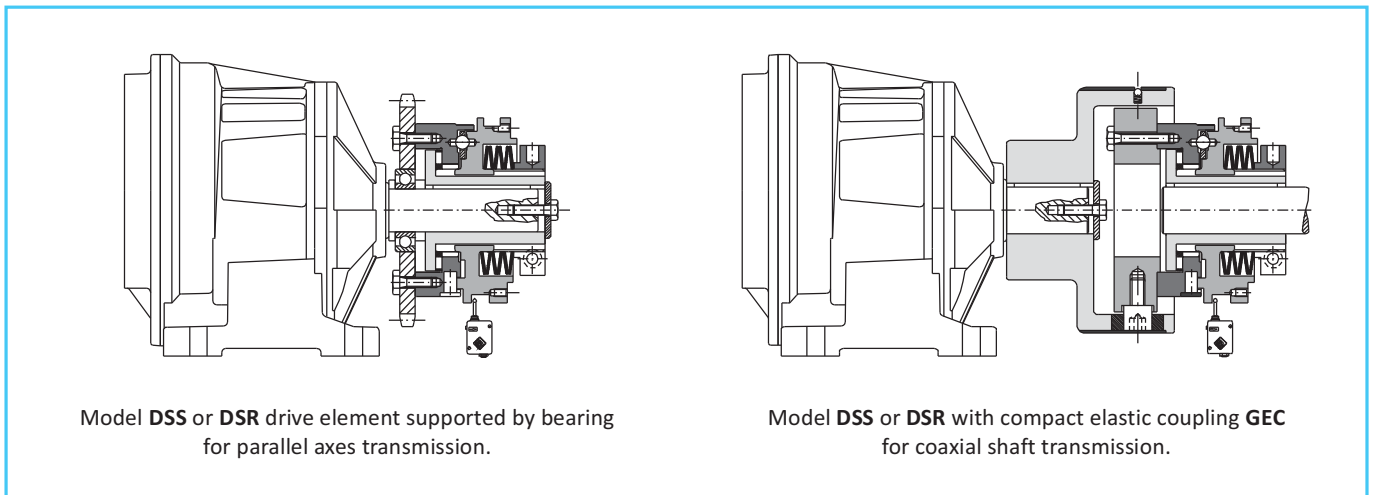

Model DSS or DSR drive element supported by bearing for parallel axes transmission.

Model DSS or DSR with compact elastic coupling GEC for coaxial shaft transmission.



ELECTROMECHANICAL SWITCH "EM1"

- Die-cast aluminium box with rotection level **IP57** DIN 40050.
- Adjustment of the lever end position possible.
- Operation temperature range from -10°C to $+85^{\circ}\text{C}$.
- Three different options of voltage input: 15A-250VCA; 5A-24VCC; 0,2A-250VCC.
- 1 or 2 contacts available.
- Initial stroke 0,5 mm, Extra stroke: $4 \div 8$ mm depending on setting (possible in a range of 6 mm).

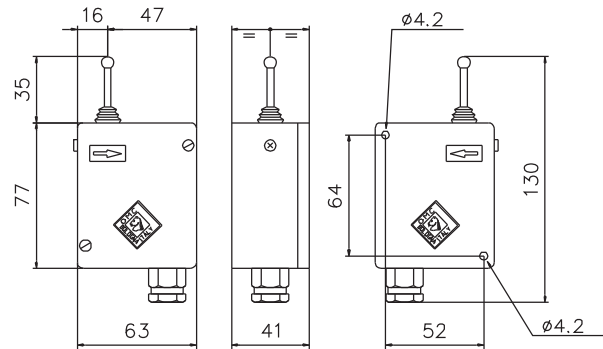
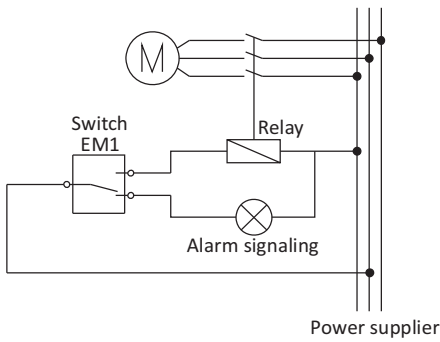

Weight: 350g

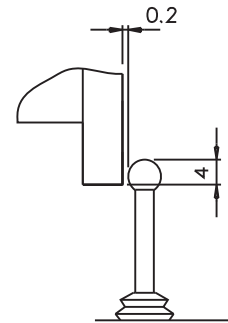

PROXIMITY SENSOR "PRX"

- Standard version: Brass cover with protection level **IP67** DIN 40050.
- Electric contact: $5 \div 24$ VdC.
- Frequency: 2000 Hz.
- Output: NPN (N.O.-N.C.) – PNP (N.O.-N.C.).
- Operating distance: max 1 mm.
- Cable length: 2 m (3x0,2).

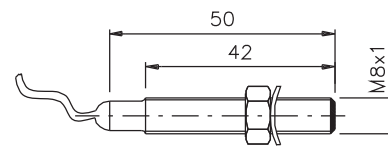
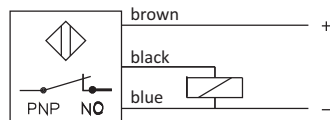
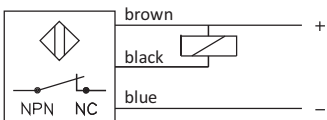
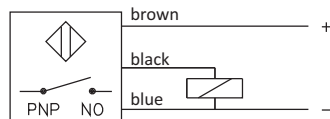
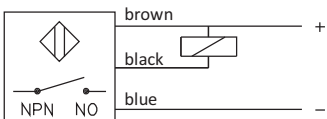

Weight: 50g

